

# PEMA COLUMN & BOOMS

## HD 7X7

### HEAVY DUTY SERIES

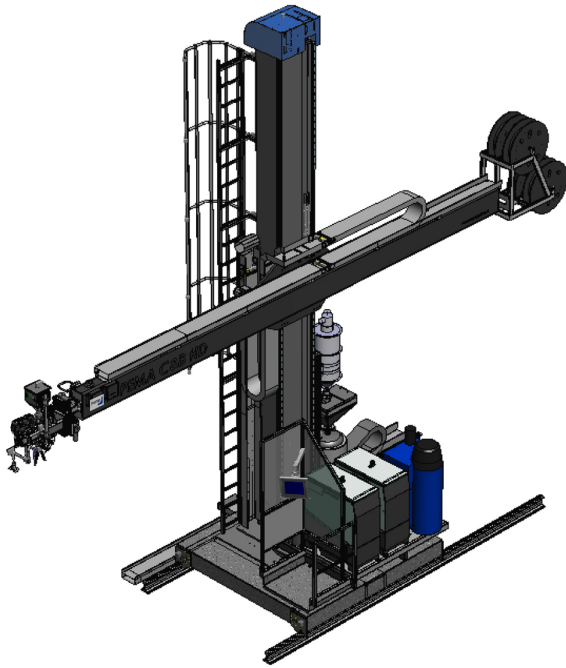

#### Technical data

Vertical reach [A] (mm)	1150 - 8150
Lifting speed (mm/min)	2000
Boom reach from c-c [B] (mm)	1250 - 8250
Total height [D] (mm)	9300
Boom speed (mm/min)	200 - 2500
Boom front end loading (kg)	250
Boom rear end loading (kg)	250
Rail span; inside-inside [E] (mm)	2350
Column rotation (motorized)	360°
Column rotation speed (min/360°)	2
Max. turning radius [F] (mm)	9500
Rail car speed (mm/min)	2500
Total weight (approx.) (kg)	9800

Due to continuous R&D, Pemamek Ltd reserves the right to change the specification without notice.

## PEMA COLUMN&BOOMS

PEMA Column & Booms are designed for high performance and meet the demanding standards of high quality production.

The powerful efficiency is based on the innovative integration with PEMA handling equipment, which all together are controlled by PEMA WeldControl 100 management tool.

PEMA C&B can be equipped with welding accessories and processes to fulfill customer's production requirements.

An essential part of efficiency and safety in heavy welding jobs is that your material handling, welding manipulator and welding power sources works hand-in-hand.

- Ideal for hard automation welding solutions
- Flexible, modular construction
- Wide selection of accessories
- Advanced and modern user interface
- Three product families, reach combinations up to 10x10m
- Full integration with all PEMA material handling equipment
- Possible processes to Column & Booms:
  - TIG
  - GMAW
  - SAW (single, twin, tandem and multi-arc)
  - Cladding with wire or strip

### BETTER PRODUCTIVITY

A cost-effective way to improve productivity, welding quality and safety

### EASY INTEGRATION

Easy to integrate with PEMA positioners and roller beds.

### MODULARITY

Depending on the case, every Column & Boom can be modularly customized to best suit the task at hand.



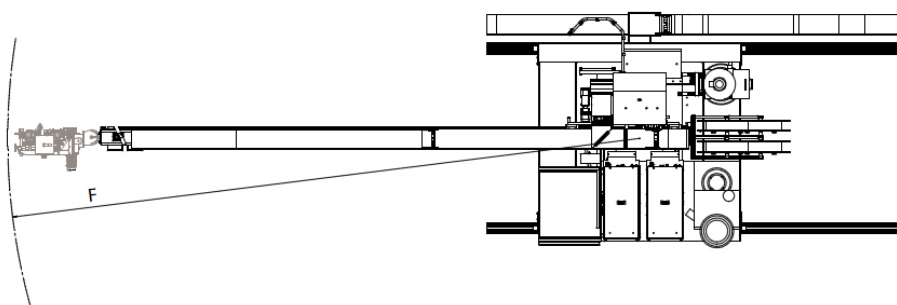
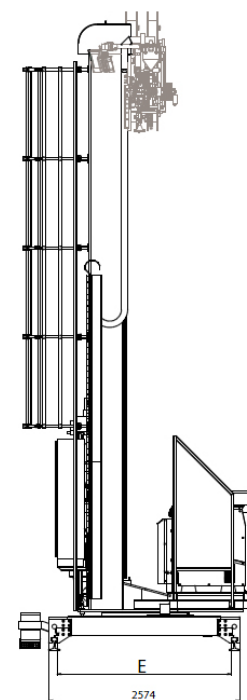
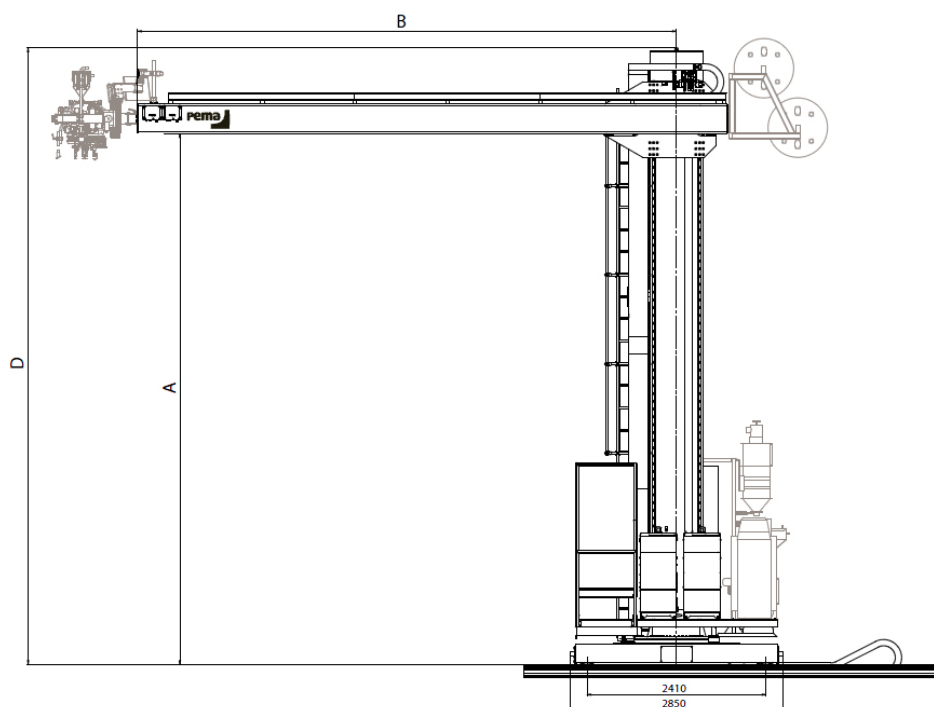

### Optional accessories

- Welding equipment
- Cross slides
- Flux handling
- Wire reels
- Control systems
- Camera
- Seam tracking
- Rails and energy chain

### PEMAMEK LTD

Lamminkatu 47, FI-32200 Loimaa, Finland  
Tel: +358 10 501 61  
Email: [info@pemamek.com](mailto:info@pemamek.com) [www.pemamek.com](http://www.pemamek.com)